

TECHNICAL SPECIFICATIONS

Engine

Engine Model	WEICHAH WP10.5H
Number of Cylinders	6
Max. Torque/Speed	1470N·m/(1200-1600)rpm
Displacement	9.726L

Hydraulic system

Max. Main Pump Flow	576L/min
Main Safety Valve Pressure	34.3MPa

Main Performance

Bucket Digging Force	218kN
Arm Digging Force	169kN
Max. Traction Force	289kN
Max. Walking Speed	5.4km/h
Min. Walking Speed	3.0km/h
Rotary Speed	7.8r/min
Gradeability	35°
Ground Pressure	69kPa

Oil Capacity

Fuel Tank	630L
Hydraulic Tank	340L
Engine Oil	38L



LOVOL HEAVY INDUSTRY GROUP CO.,LTD.

Address: No. 75, Huanghe East Road, Huangdao District, Qingdao City, Shandong Province, China.

Website: en.wlovol.com

E-mail: lovol_overseas@global.lovol.com

TEL: +86-532-86907190

Facebook: Cons Lovol

As manufacturer, LOVOL has right to constantly upgrade and improve our products without informing to customers. The pictures in literatures are for reference only, the detailed specifications are subject to real products.



Rated Power	247kW/2000rpm
Operating Weight	37000kg
Bucket Capacity	1.9 m ³

FR375F

EXCAVATOR



EFFICIENCY

Using Weichai Linde powertrain technology, the operating efficiency of the whole machine is increased by 15% compared with the generation E, and the fuel efficiency is increased by more than 20%.

Engine thermal efficiency leads the industry. The minimum fuel consumption is 180g / kWh.

Large displacement main pump, the main pump displacement increased by 12.5%. Using plunger pack sliding boots, 21° swing angle technology, compact structure, high power density. Double variable cylinder accurate inclined plate control, good consistency, faster response speed, main pump displacement output accuracy a higher accuracy, accurate output of the required flow.

Large displacement displacement, low rotation speed; Large torque, and high power. Power increased to 247KW; torque, increased to 1470N · m.

The large flow main valve is adopted, the diameter of the valve core increases by 21.4%, and the flow capacity of the main valve is increased by 50L / min. Linde exclusive custom tuning, internal flow channel optimization, smaller pressure loss, better response.

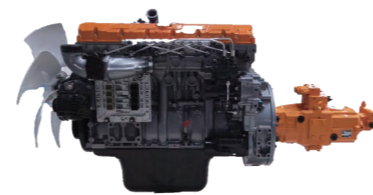

RELIABILITY

Weichai high-end H platform engine, the life of up to 30,000 hours.

Noise reduction wheel system

Low speed ratio, noise reduction fan, air conditioning high position, convenient maintenance.

High efficiency intake system

Meet the requirements of 3,500 meters without reducing the power.

Large capacity oil bottom shell

Meet the 35° inclination requirements and 500 hours of oil change cycle, structural reinforcement, noise suppression.

Machine filter, burning filter far transmission

Convenient maintenance, maintenance cycle of 500h, standard fuel water hanbao.

Rear gear room

Reduce NVH.

COMFORT



Safe and comfortable: Driving meets the ROPS regulatory requirements, and driving is safer.

Adopt new structure, extended to meet 50 tons of ROPS regulatory requirements, safer.
Panoramic skylight, break through the concept of conventional construction machinery.

All new air duct and air outlet design, storage space increase.

After NFD analysis, the air conditioning duct has lower wind resistance and lower noise. With the optimized air outlet position, it provides a cool and comfortable space for drivers in the hot summer.
More storage space, can accommodate the driver's daily trivial items, to provide a cleaner driving environment.

Seat improvement and upgrade, standard rear view camera.

Wideseat wider, ride more comfortable; SIP point three adjustment to meet the needs of different height.
With a standard rear-view camera, the driver can easily find obstacles behind the car and improve driving safety.

INTELLIGENCE



The newly developed Leo intelligent operating system can realize power system management, intelligent interaction, automatic identification of working conditions, auxiliary operation, personalized customization and other functions.

Intelligent vehicle control

The driver can remotely control the excavator by using the mobile phone to connect to the Bluetooth in the vehicle to power on/off, start/off, turn on/off the air conditioning, turn on/off the lights, and also enable simple mobile phone remote operation, etc.

Intelligent multimedia

the driver can use the mobile phone to answer the phone and play music through the monitor.

Intelligent welcome

When the cab is opened, the interior reading light and foot light are illuminated and the WEICHAI LOVOL logo is displayed on the underside of the cab.

Accompanying you

Home At night, when the driver finishes work and leaves the excavator, the work light is switched off on a delayed basis to light the way home.



INCREASE YOUR PRODUCTIVITY AND PROFIT WITH LOVOL ATTACHMENTS

You can easily expand the performance of your machine by utilizing any of the variety of LOVOL Attachments.
Each LOVOL Attachments is designed to fit the weight and horsepower of LOVOL Excavator for improved performance, safety, and stability.



STANDARD CONFIGURATION

Engine

- Turbocharged 4 stroke water-cooling direct injection type
- Complying with China Stage III emissions
- Automatic idle system
- Engine oil pan drain valve
- Radiator with protective net
- Double filter elements dry air filter element
- Air pre-filter
- Air intake heater
- Fan guard

Hydraulic System

- Automatic hydraulic system (confluence system)
- Anti-swing valve
- Boom and arm block valve
- Multi-stage filtration system
- Cylinder buffer device
- Auxiliary hydraulic valve
- Automatic two-speed travel motor

Electronic Control System

- 24V power supply
- Diagnostic interface
- Emergency stop switch
- Display brightness adjustment
- Maintenance tips
- Automatic diagnostic system
- Automatic idle system
- One-touch pressure augmentation
- Safe stop / start function
- Main power switch
- Anti-theft system
- Engine starting protection
- Multilingual display

Cab

- Ashtray
- Cigar lighter
- Seat belt
- Front sunshade
- Storage box
- Escape hammer
- Thermostatically controlled air conditioner
- Shock absorber (silicone oil and rubber pad)
- Flexible antenna
- Radio (with interfaces of MP3 and USB)
- Hydraulic safety lock
- Sun-protection safety glass
- Floor mat
- Large storage area
- Pull-up front window
- Removable lower windshield
- Sunshade window
- Front-bottom glass protective screening
- Wipers
- Open skylight

Swing Platform

- Passage with railing
- Tool box
- Anti-skid plate
- Large pedal
- Large armrest
- Bottom protection plate
- Anti-collision beam

Chassis

- Fixed chassis
- 600mm, three-tooth track shoe

TECHNICAL SPECIFICATIONS

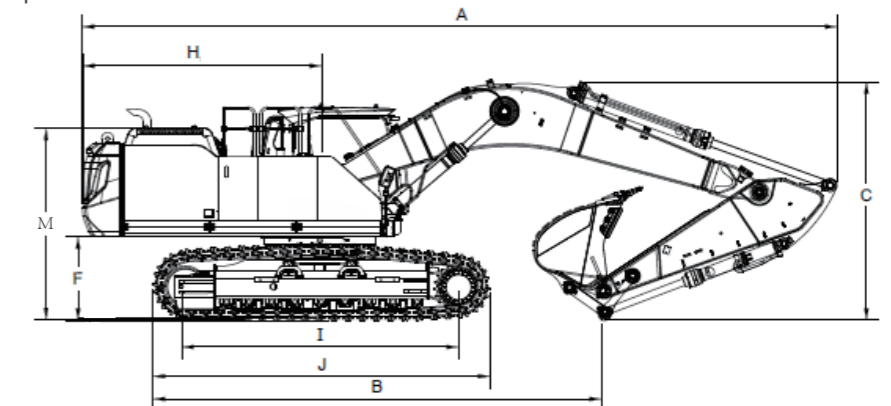
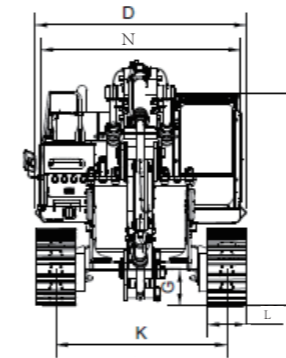

Working Range

Max. Digging Height	1	10025mm
Max. Dumping Height	2	7070mm
Max. Digging Depth	3	6960mm
Max. Vertical Digging Depth	4	4707mm
Max. Digging Radius	5	10770mm
Max. Ground Digging Radius	6	10556mm
Min. Turning Radius	7	4427mm

Dimensions

Shipping Length	A	11350mm
Shipping Ground Length	B	6760mm
Boom Height	C	3615mm
Shipping Width	D	3200mm
Cab Height	E	3246mm
Ground Clearance of Counter Weight	F	1224mm
Min. Ground Clearance	G	516mm
Tail Turning Radius	H	3610mm
Length to Center of Rollers	I	4140mm
Track Length	J	5070mm
Track Gauge	K	2590mm
Track Shoe Width	L	600mm
Hood Height	M	2892mm
Rotary Platform Width	N	3025mm

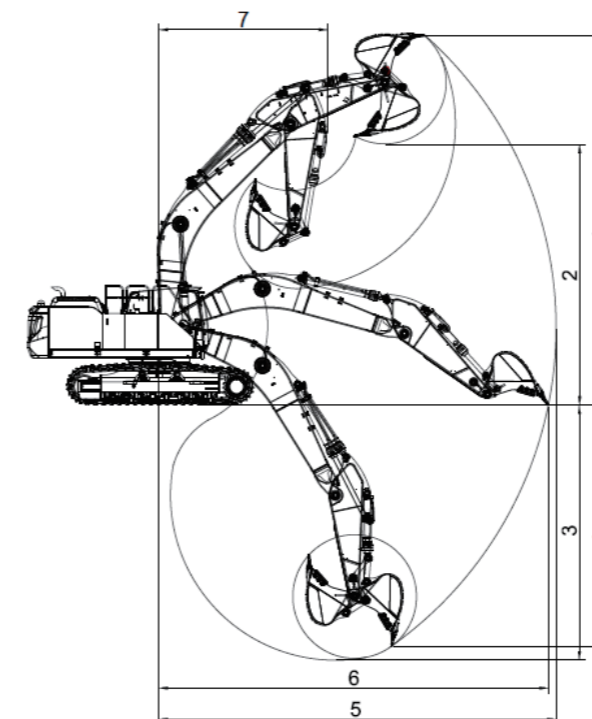

Other Specifications

Boom Length	6470mm
Arm Length	3190mm
Track Section Number (each side)	48
Track Roller Number	9