

## TECHNICAL SPECIFICATIONS



### Engine

Engine Model	WEICHAI WP10.5H
Number of Cylinders	6
Max. Torque/Speed	1470N·m/(1200-1600)rpm
Displacement	9.5L



### Hydraulic system

Max. Main Pump Flow	2*357L/min
Main Safety Valve Pressure	34.3MPa



### Main Performance

Bucket Digging Force	245kN
Arm Digging Force	214kN
Max. Traction Force	306kN
Max. Walking Speed	5.1km/h
Min. Walking Speed	3.1km/h
Rotary Speed	8.5r/min
Gradeability	70°
Ground Pressure	67kPa



### Oil Capacity

Fuel Tank	630L
Hydraulic Tank	265L
Engine Oil	39.5L



### LOVOL HEAVY INDUSTRY GROUP CO.,LTD.

Address: No. 75, Huanghe East Road, Huangdao District, Qingdao City, Shandong Province, China.

Website: [en.wlovol.com](http://en.wlovol.com) E-mail: [lovol\\_overseas@global.lovol.com](mailto:lovol_overseas@global.lovol.com) TEL: +86-532-86907190 Facebook: Cons Lovol

As manufacturer, LOVOL has right to constantly upgrade and improve our products without informing to customers. The pictures in literatures are for reference only, the detailed specifications are subject to real products.

Rated Power **247kW/2000rpm**  
 Operating Weight **41500kg**  
 Bucket Capacity **2.2m³**

**FR420F**  
 EXCAVATOR



## RELIABILITY

Weichai high-end H platform engine, the life of up to 30,000 hours.

the rotary platform adopts the heavy-load structure, the stress is reduced by more than 40%, the chassis adopts the mine special chassis, 45-ton four-wheel area.

The platform architecture is upgraded, the main boom installation spacing is increased, and the carrying capacity is greatly improved;

The main plate is thickened, and the working stress is reduced by more than 40%;

Cancel the adjustment pad to avoid the loosening or fracture of the installation bolt caused by the sliding of the adjustment pad.

The reinforced four wheel area, the carrier roller adopts double support structure;

The rotary support modulus is changed from 14 to 16;

The heat treatment process of crawler components is upgraded, and the wear resistance is improved by 60%.

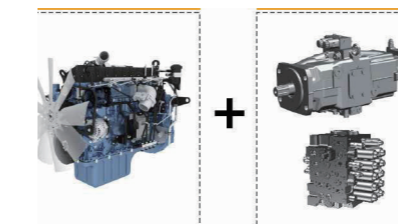
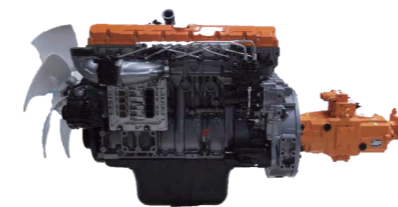
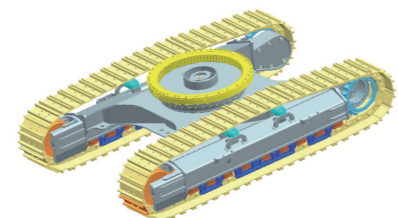
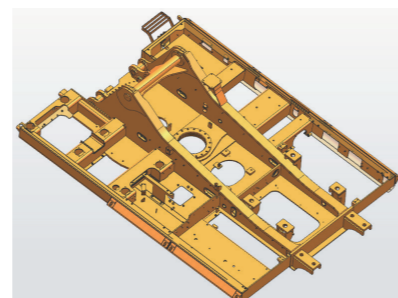

## EFFICIENCY

Using Weichai powertrain technology, the operating efficiency of the whole machine is increased by 15% compared with the generation E, and the fuel efficiency is increased by more than 20%.

Engine thermal efficiency leads the industry;  
The minimum fuel consumption is 180g / kWh.

Large displacement displacement, low rotation speed;  
Large torque, and high power. Power increased to 247KW; torque, increased to 1470N · m.

Large displacement main pump, the main pump displacement increased by 12.5%.

Using plunger pack sliding boots, 21° swing angle technology, compact structure, high power density.

Double variable cylinder accurate inclined plate control, good consistency, faster response speed, the main pump displacement output accuracy is higher, accurate output of the required flow.

The large flow main valve is adopted, the valve core diameter increases by 21.4%, and the flow capacity of the main valve is increased by 50L / min.

Linde exclusive custom tuning, internal flow channel optimization, smaller pressure loss, better response.

## INTELLIGENCE



Lovol's new smart OS covers functions of power system management, smart interaction, automatic identification to working condition, aided operation personalized service, etc.

### Smart control

After the driver uses the mobile phone to connect the car Bluetooth, he can remotely control the excavator to power on/off, start/turn off, turn on/off the air conditioning, turn on/off the light, and also realize simple remote work on the mobile phone.

### Intelligent multimedia

After the driver uses the mobile phone to connect the car Bluetooth, he can answer calls and play music through the panel.

### Intelligent fuse box

The traditional safety box is upgraded into an intelligent power management module BCM, which has automatic protection and intelligent recovery functions.

## COMFORT



**Driving meets the ROPS regulatory requirements, and driving is safer.**

The new structure is upgraded to meet the 50 ton ROPS regulation, which is safer.

Panoramic skylight, breaking through the common sense of conventional construction machinery.

**New air duct and outlet design, and bigger storage space.**

After NFD analysis, the air conditioning duct has lower wind resistance, lower noise, and the optimized outlet location provides a cool and comfortable space for the driver in the hot summer.

More storage space can accommodate the driver's daily trivial items, providing a cleaner driving environment.

**Upgraded seat with standard rear-view camera.**

Wider seat surface is more comfortable; SIP points are adjusted at three different levels to meet different height requirements.

## INCREASE YOUR PRODUCTIVITY AND PROFIT WITH LOVOL ATTACHMENTS

You can easily expand the performance of your machine by utilizing any of the variety of LOVOL Attachments. Each LOVOL Attachments is designed to fit the weight and horsepower of LOVOL Excavator for improved performance, safety, and stability.



## STANDARD CONFIGURATION

### Engine

- Turbocharged, 6-cylinders, water-cooling, direct injection
- Radiator with protective fence
- Air Pre-filter
- Air intake heater
- Fan guard
- Double filters, dry air filter
- Engine oil pan with oil drain valve
- Automatic idle speed system

### Hydraulic System

- Automatic hydraulic system (flow confluence system)
- Multistage filtration system
- Anti-sway valve
- Boom and stick locking valve
- Cylinder buffer device
- Anti-slope turning device
- Hydraulic hammer pipeline
- Pilot buffer valve (rotary, stick, boom)

### Electronic Control System

- 24V power battery
- Monitor brightness adjustment
- Maintenance tips
- Safe stop & start function
- Master switch
- Engine start protection
- Multilingual display
- Cab ceiling light
- Diagnostic interface
- Emergency stop switch
- Automatic diagnosis system
- Automatic idle speed system
- One-touch pressure enhancement
- Anti-theft system

### Cab

- Ashtray
- Cigarette lighter
- Seat belt
- Shade plate
- Storage compartment
- Emergency hammer
- Air conditioner
- Audio speaker
- Shock absorber
- Flexible aerial
- Radio
- Hydraulic safety locking rod
- Sun proof safety glass
- Floating seat

### Swing Platform

- Toolbox
- Large pedal
- Large handrail
- Bottom guard plate
- Anti-crash beams
- Anti-skid plates
- Passage with handrails
- Cad protection device
- Spare parts box

### Chassis

- Fixed chassis
- 600mm triple tooth track plate

## TECHNICAL SPECIFICATIONS

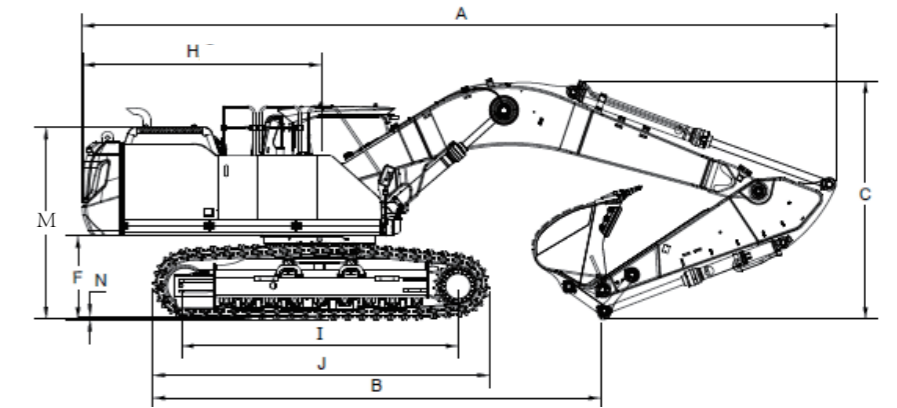
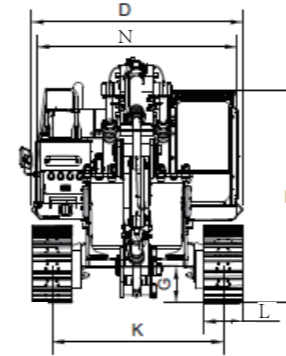

### Working Range

Max. Digging Height	1	10055mm
Max. Dumping Height	2	7090mm
Max. Digging Depth	3	6940mm
Max. Vertical Digging Depth	4	4661mm
Max. Digging Radius	5	10580mm
Max. Ground Digging Radius	6	10790mm
Min. Turning Radius	7	4430mm

### Dimensions

Shipping Length	A	11350mm
Shipping Ground Length	B	6840mm
Boom Height	C	3648mm
Shipping Width	D	3340mm
Cab Height	E	3322mm
Ground Clearance of Counter Weight	F	1299mm
Min. Ground Clearance	G	588.5mm
Tail Turning Radius	H	3610mm
Wheel Tread	I	4320mm
Track Length	J	5390mm
Track Gauge	K	2740mm
Track Shoe Width	L	600mm
Hood Height	M	2723mm
Rotary Platform Width	N	3025mm

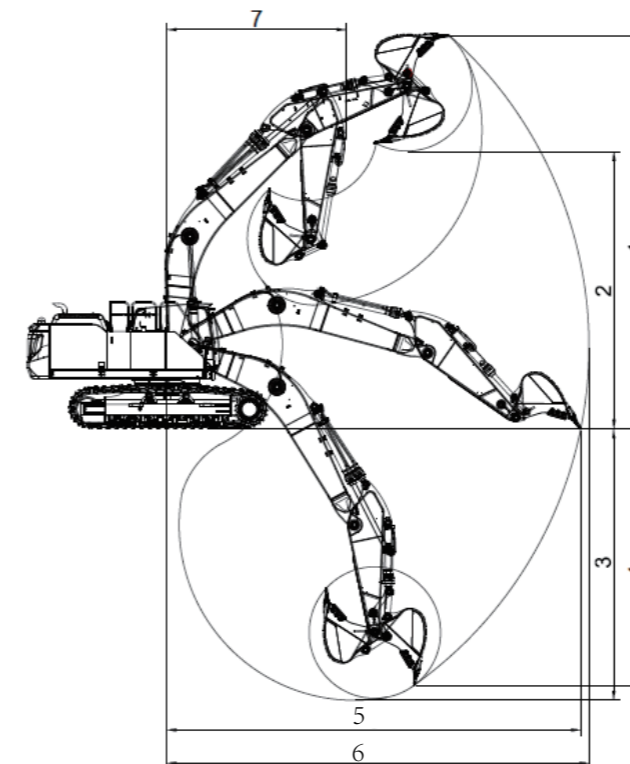

### Other Specifications

Boom Length	6500mm
Arm Length	2800mm
Track Section Number (each side)	51
Track Roller Number	9